

DATA SHEET

TFT MODULE

MODULE NO. :

SDT09603N-A11

Customer:
Approved by:

Sinda Display Technology Co., Ltd.		
Approved by	Checked by	Prepared by



CONTENTS

1. GENERAL SPECIFICATIONS	4
2. MECHANICAL DRAWING	5
3. INPUT/OUTPUT TERMINALS	6
4. ABSOLUTE MAXIMUM RATINGS.....	6
5. ELECTRICAL CHARACTERISTICS.....	6
6. OPTICAL CHARACTERISTICS.....	8
7. ENVIRONMENTAL / RELIABILITY TESTS	11
8. PACKING.....	12
9. PRECAUTIONS FOR USE OF LCD MODULES.....	13

1. GENERAL SPECIFICATIONS

	Feature	Spec
Display Spec	Size	0.96 inch
	Resolution	80(RGB) x 160
	Interface	4-SPI
	Technology type	a-si TFT
	Pixel pitch(mm)	0.135 x 0.135
	Display colors	262k
	TFT Driver IC:	NV3022B
	Viewing Direction	ALL
Mechanical Characteristics	LCM(W x H x D)(mm)	13.50 x 27.95 x 1.90(MAX)
	Active Area(mm)	10.80x21.70
	Weight (g)	10g
	LED Numbers	1 LEDS

Note 1: Viewing direction for best image quality is different from TFT definition; there is a 180 degree shift.

Note 2: Requirements on Environmental Protection: RoHS.

Note 3: LCM weight tolerance: +/-5%.

2. MECHANICAL DRAWING

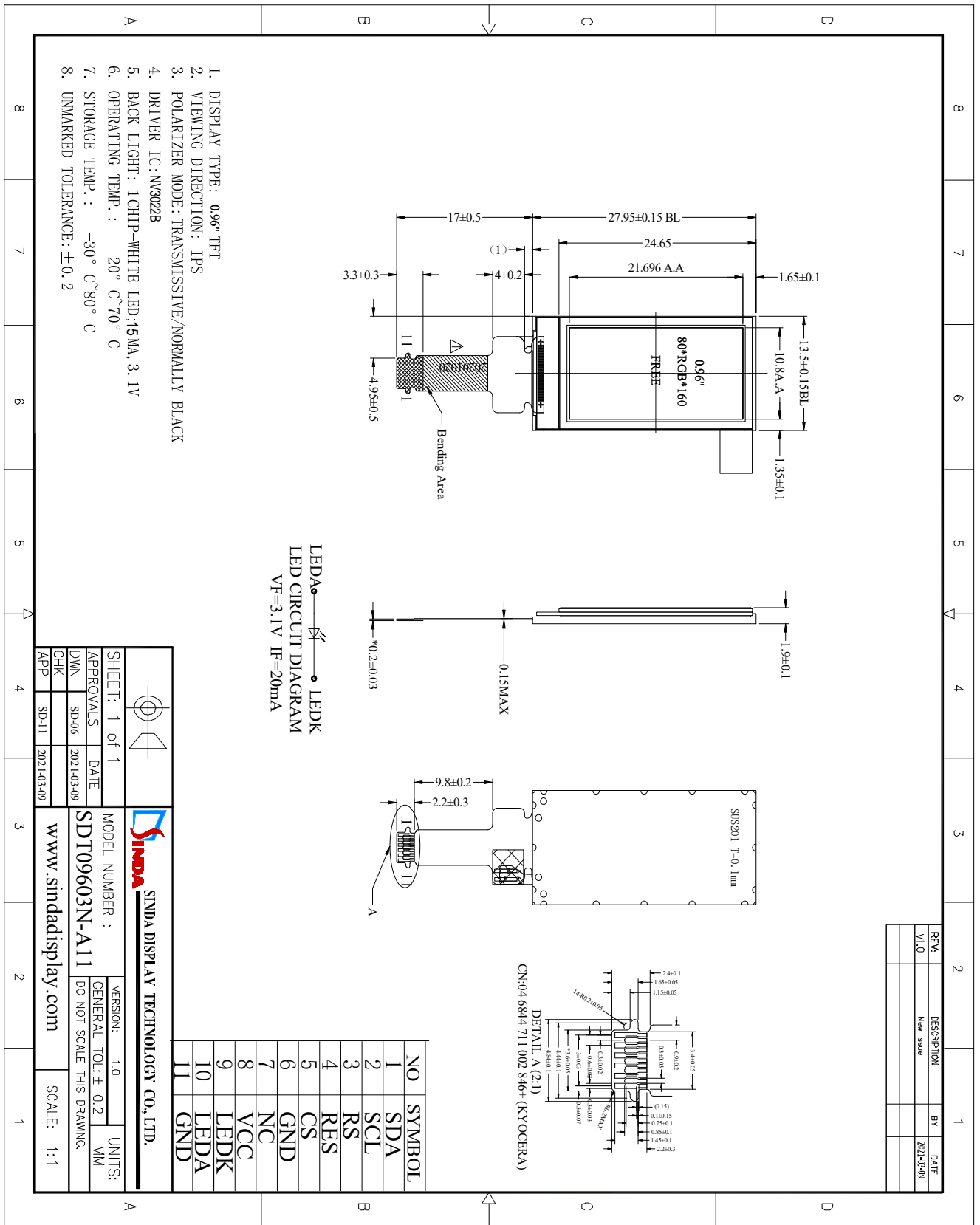

3. INPUT/OUTPUT TERMINALS

No.	Symbol	Description
1	SDA	Serial data pin
2	SCK	Serial clock pin.
3	RS	Display data/command Selection Pin
4	RESET	This signal reset pin
5	CS	Chip select input pin
6	GND	Ground
7	NC	No connector
8	VDD	Power supply
9	LED-K	Backlight LED cathode
10	LED-A	Backlight LED Anode.
11	GND	Ground

4. ABSOLUTE MAXIMUM RATINGS

Item	Symbol	MIN	MAX	Unit	Remark
Supply Voltage	V _{DD}	-0.3	+4.6	V	2
Operating Temperature	T _{OPR}	-20	70	°C	
Storage Temperature	T _{STG}	-30	80	°C	

5. ELECTRICAL CHARACTERISTICS**5.1 Driving TFT LCD Panel**

Ta = 25 °C

Item	Symbol	MIN	TYP	MAX	Unit	Remark
Digital Supply Voltage	IOVDD	-	1.65	1.8/2.8	V	
Analog Supply Voltage	VDD	2.6	3.0	3.3	V	
Logic High level input voltage	V _{IH}	0.7*VDD	-	VDD	V	
Logic Low level input voltage	V _{IL}	0	-	0.3* VDD	V	
Logic High level Output voltage	V _{IH}	0.7*VDD	-	VDD	V	
Logic Low level Output voltage	V _{IL}	0		0.2* VDD	V	

5.2. Driving Backlight

Item	Symbol	MIN	TYP	MAX	Unit	Condition
Forward Current	I _F	-	15	20	mA	IF=15mA
Forward Voltage	V _F	2.9	3.1	3.3	V	
Backlight Power consumption	W _{BL}	-	46	-	nW	
Luminance for LCM	-	120	150		Cd/m ²	

Note: 1. the figure below shows the connection of backlight LED.

**LED CIRCUIT**

5.3. Display Serial Interface Timing Characteristics (4-line SPI system)

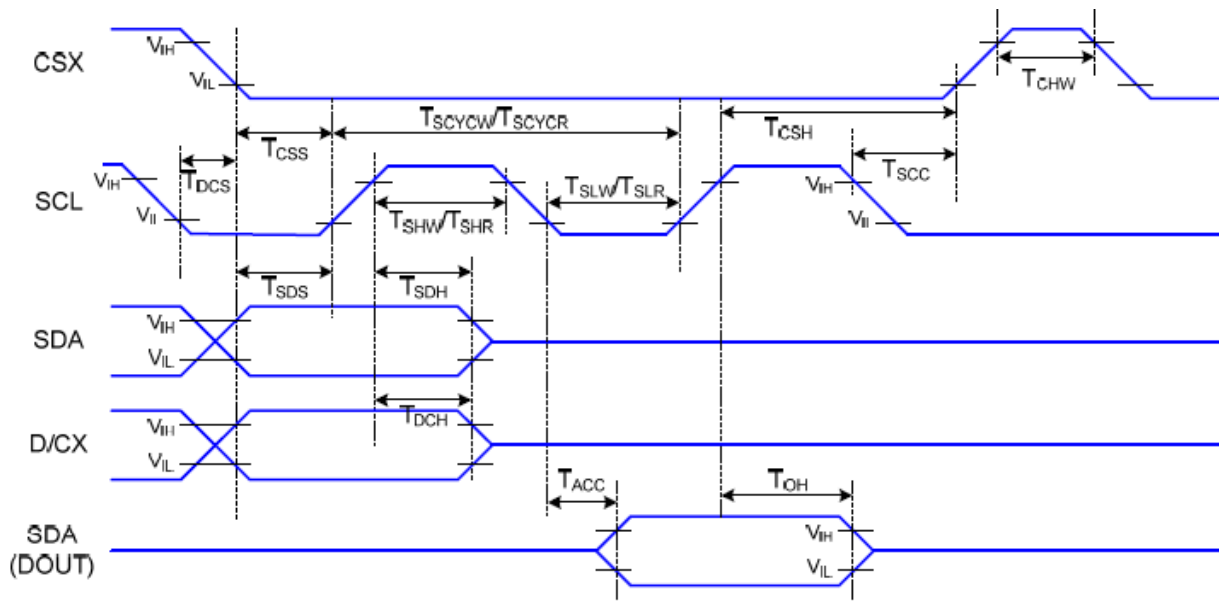

Signal	Symbol	Parameter	MIN	MAX	Unit	Description
CSX	TCSS	Chip select setup time (write)	15		ns	
	TCSH	Chip select hold time (write)	15		ns	
	TCSS	Chip select setup time (read)	60		ns	
	TSCC	Chip select hold time (read)	65		ns	
	TCHW	Chip select "H" pulse width	40		ns	
SCL	TSCYCW	Serial clock cycle (Write)	66		ns	-write command & data ram
	TSHW	SCL "H" pulse width (Write)	30		ns	
	TSLW	SCL "L" pulse width (Write)	30		ns	
	TSCYCR	Serial clock cycle (Read)	150		ns	-read command & data ram
	TSHR	SCL "H" pulse width (Read)	60		ns	
	TSLR	SCL "L" pulse width (Read)	60		ns	
D/CX	TDCS	D/CX setup time		0	ns	
	TDCH	D/CX hold time	10		ns	
SDA (DIN) (DOUT)	TSDS	Data setup time	10		ns	For maximum CL=30pF For minimum CL=8pF
	TSDH	Data hold time	10		ns	
	TACC	Access time	10	50	ns	
	TOH	Output disable time		50	ns	

6. OPTICAL CHARACTERISTICS

Items	Symbol	Condition	Specifications			Unit	Remark
			Min.	Typ.	Max.		
Contrast Ratio	CR	$\theta = 0$	150	180	-	-	Note
Response Time	T_R	25°C	-	20	30	ms	
	T_F		-	20	30	ms	
Chromatics	Red	X_R	0.611	0.613	0.615	-	
		Y_R	0.333	0.335	0.337	-	
	Green	X_G	0.305	0.307	0.309	-	
		Y_G	0.558	0.560	0.562	-	
	Blue	X_B	0.133	0.135	0.137	-	
		Y_B	0.158	0.160	0.162	-	
White	X_W	0.304	0.316	0.328	-		
	Y_W	0.314	0.337	0.368	-		
Viewing angle	Hor.	$\phi R(3 \text{ o'clock})$	80	85	-	deg.	
		$\phi L(9 \text{ o'clock})$	80	85	-		
	Ver.	$\theta U(12 \text{ o'clock})$	80	85	-		
		$\theta D(6 \text{ o'clock})$	80	85	-		
Uniformity	U		75	80			
NTSC ratio				50		%	
Luminance	L_v		120	150		cd/m ²	
Operating life time		$I_{BL}=15\text{mA}$	--	50000		h	

Note 1: Definition of Contrast Ratio (CR):

The contrast ratio can be calculated by the following expression.

$$\text{Contrast Ratio (CR)} = L_{63} / L_0$$

L63: Luminance of gray level 63

L0: Luminance of gray level 0

$$CR = CR(10)$$

CR (X) is corresponding to the Contrast Ratio of the point X at Figure in Note 5.

Note 2: Definition of Response Time (TR, TF):

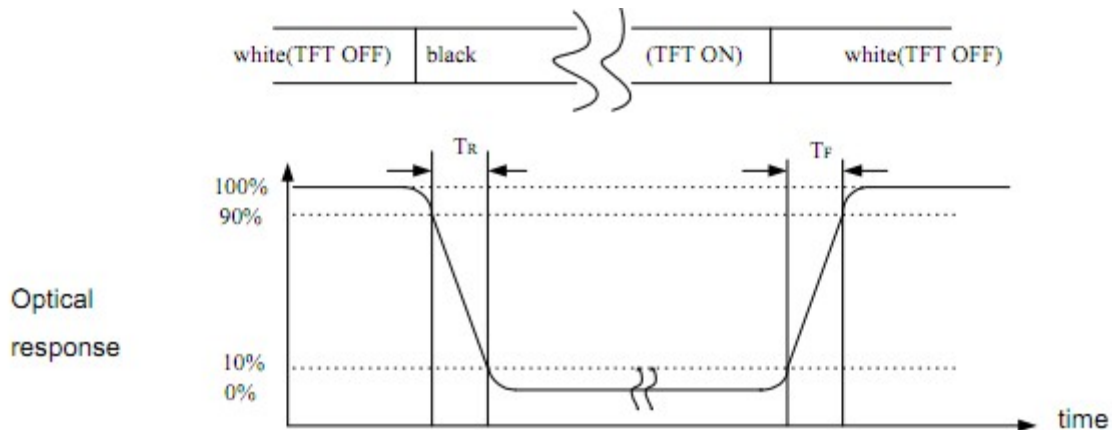

Figure 2

Note 3: Viewing Angle:

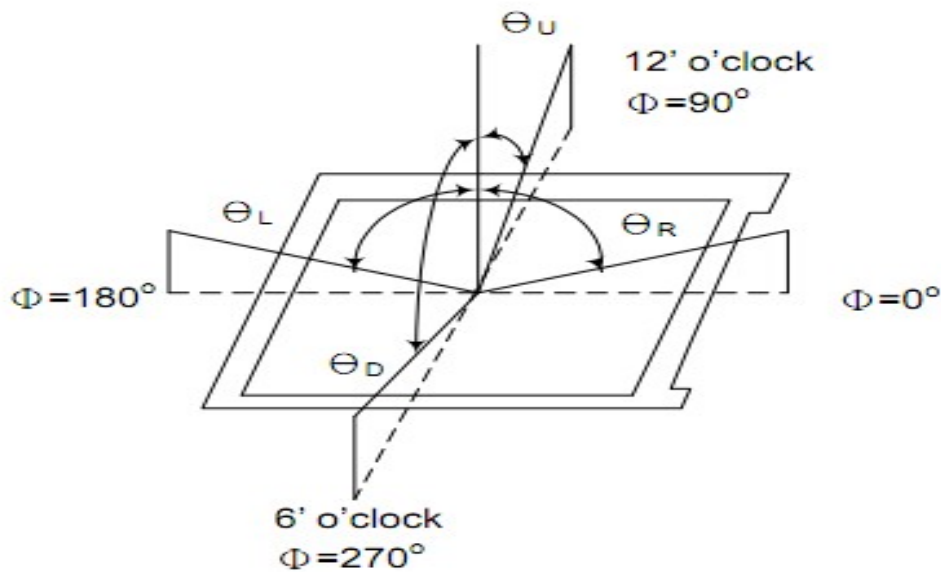

Figure 3

The above “Viewing Angle” is the measuring position with Largest Contrast Ratio; not for good image quality. View Direction for good image quality is 6 O’clock. Module maker can increase the “Viewing Angle” by applying Wide View Film.

Note 4: Measurement Set-Up:

The LCD module should be stabilized at a given temperature for 20 minutes to avoid abrupt temperature change during measuring. In order to stabilize the luminance, the measurement should be executed after lighting Backlight for 20 minutes in a windless room.

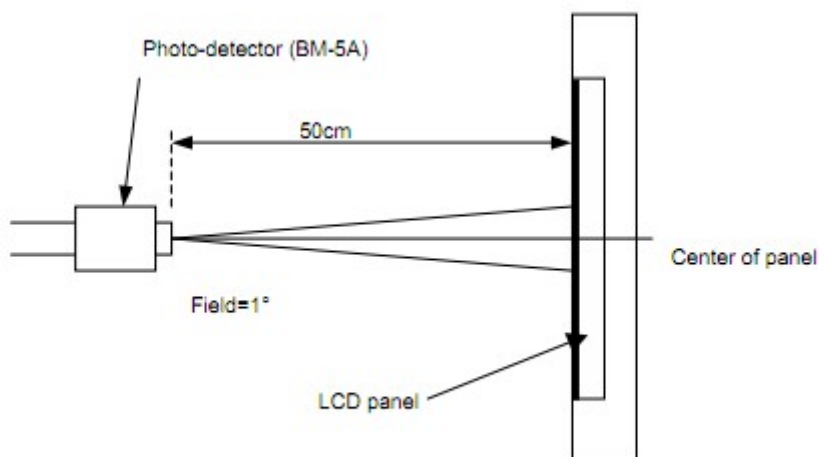

Figure 4

Note 5: Definition of colder chromaticity (CIE61747-1)

Color coordinates measured at center point of LCD.

Note 6: Definition of Luminance Uniformity

Active area is divided into 9 measuring areas (Refer Fig.2) Every measuring point is placed at the center of each measuring area.

$$\text{Luminance Uniformity}(U) = L_{\min}/L_{\max}$$

L-----Active area length W-----Active area width

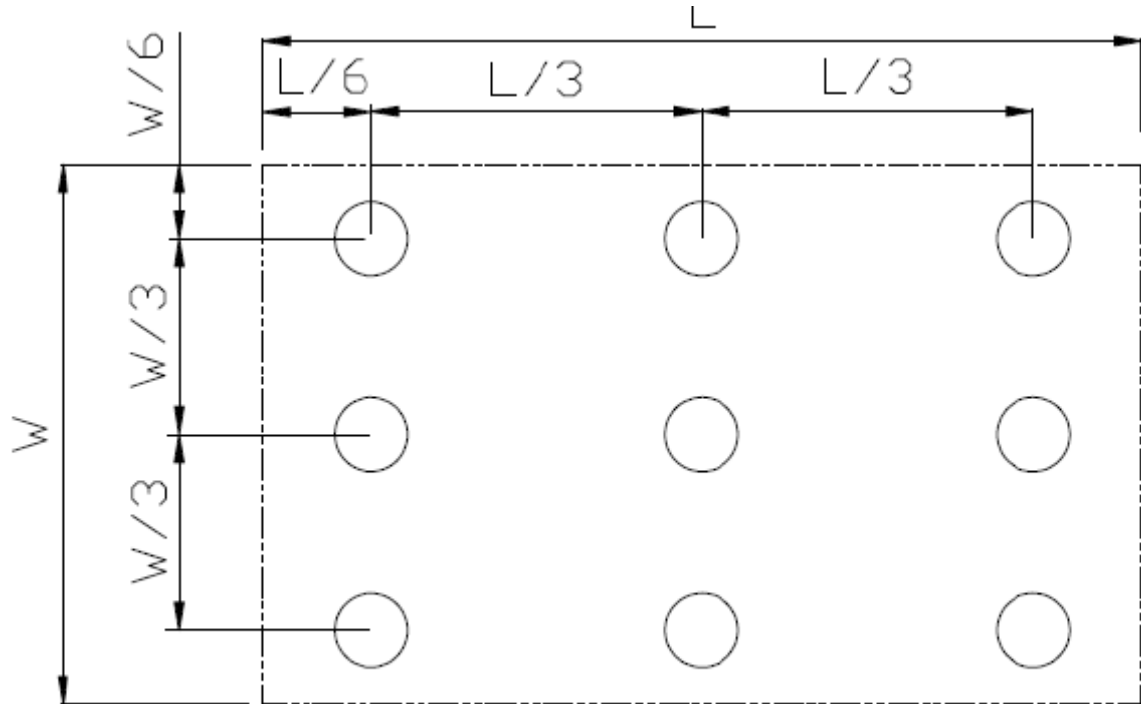

Fig. 2 Definition of uniformity

Lmax: The measured maximum luminance of all measurement position.

Lmin: The measured minimum luminance of all measurement position.

Note 7: Definition of Luminance

Measure the luminance of white state at chanter point.

7. Environmental / Reliability Tests

No	Test Item	Condition	Remarks
1	High Temperature Operation	T _s = +70°C, 96hrs	Note 1 IEC60068-2-2, GB2423. 2-89
2	Low Temperature Operation	T _a = -20°C, 96hrs	Note 2 IEC60068-2-1 GB2423.1-89
3	High Temperature Storage	T _a = +80°C, 96hrs	IEC60068-2-2 GB2423. 2-89
4	Low Temperature Storage	T _a = -30°C, 96hrs	IEC60068-2-1 GB/T2423.1-89
5	High Temperature & Humidity Storage	T _a = +60°C, 90% RH max, 96 hours	IEC60068-2-3 GB/T2423.3-2006
6	Thermal Shock (Non-operation)	-30°C 30 min ~ +80°C 30 min Change time: 5min, 30 Cycle	Start with cold temperature, end with high temperature IEC60068-2-14, GB2423.22-87
7	Electro Static Discharge (Operations)	C=150pF, R=330 Ω, 5 points/panel Air: ±8KV, 5 times; Contact: ±4KV, 5 times; (Environment: 15°C ~ 35°C, 30% ~ 60%, 86Kpa ~ 106Kpa)	IEC61000-4-2 GB/T17626.2-1998
8	Vibration (Non-operation)	Frequency range: 10~55Hz, Stroke: 1.mm Sweep: 10Hz~55Hz~10Hz 2 hours for each direction of X .Y. Z. (package condition)	IEC60068-2-6 GB/T2423.5-1995
9	Shock (Non-operation)	60G 6ms, ± X, ±Y, ± Z 3 times for each direction	IEC60068-2-27 GB/T2423.5-1998
10	Package Drop Test	Height: 80 cm, 1 corner, 3 edges, 6 surfaces	IEC60068-2-32 GB/T2423.8-1995

Note: 1. T_S is the temperature of panel's surface.
2. T_a is the ambient temperature of sample.

8. Packing

Packing Method

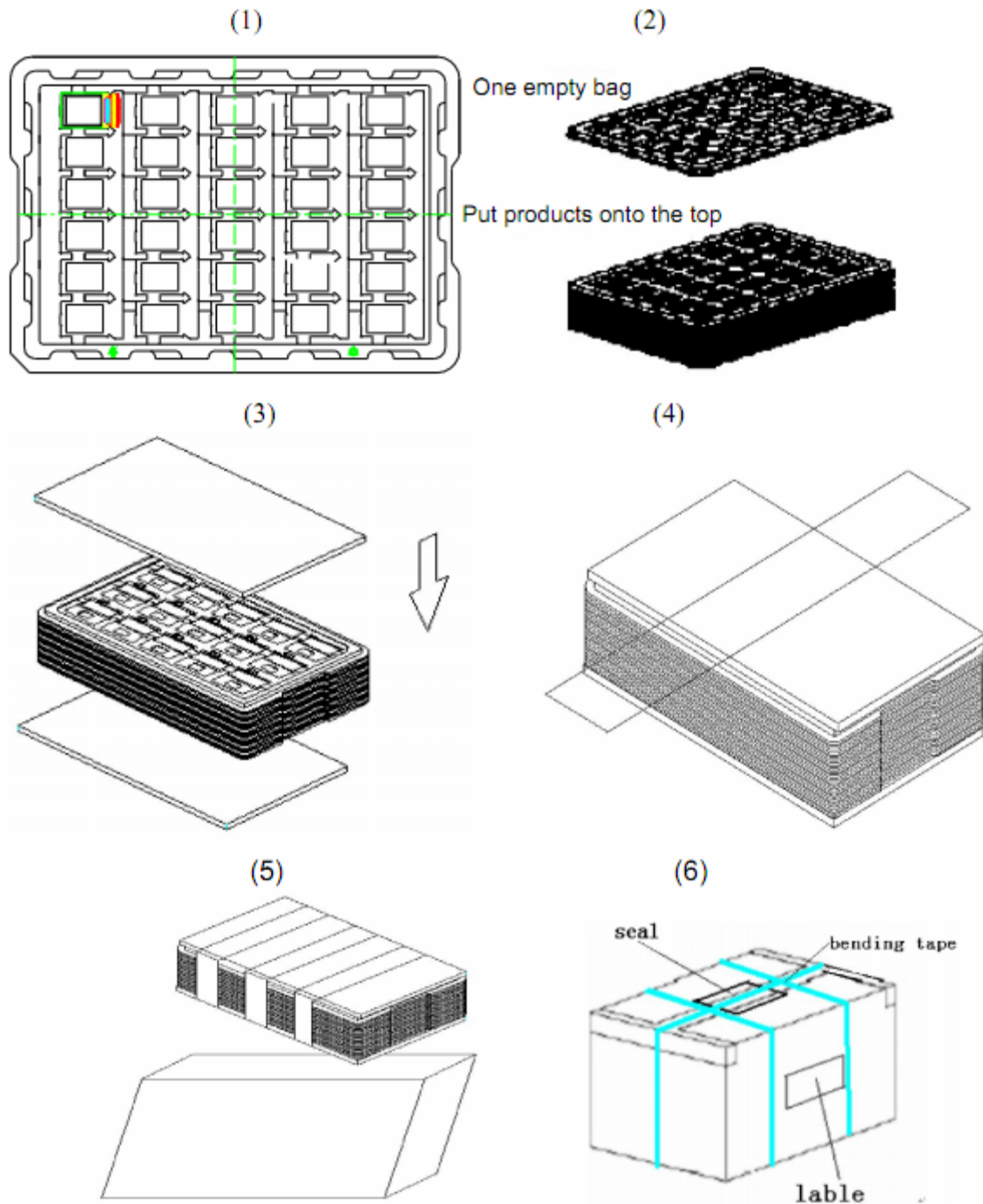

1. Put module into tray cavity:
2. Tray stacking.
3. Put 1 cardboard under the tray stack and 1 cardboard above:
4. Fix the cardboard to the tray stack with adhesive tape:
5. Put the tray stack into carton.
6. Carton sealing with adhesive tape.

9. Precautions for Use of LCD modules

9.1 Handling Precautions

9.1.1. The display panel is made of glass. Do not subject it to a mechanical shock by dropping it from a high place, etc.

9.1.2. If the display panel is damaged and the liquid crystal substance inside it leaks out, be sure not to get any in your mouth, if the substance comes into contact with your skin or clothes, promptly wash it off using soap and water.

9.1.3. Do not apply excessive force to the display surface or the adjoining areas since this may cause the color tone to vary.

9.1.4. The polarizer covering the display surface of the LCD module is soft and easily scratched. Handle this polarizer carefully.

9.1.5. If the display surface is contaminated, breathe on the surface and gently wipe it with a soft dry cloth. If still not completely clear, moisten cloth with one of the following solvents:

- Isopropyl alcohol
- Ethyl alcohol

Solvents other than those mentioned above may damage the polarizer. Especially, do not use the following:

- Water
- Ketene
- Aromatic solvents

9.1.6. Do not attempt to disassemble the LCD Module.

9.1.7. If the logic circuit power is off, do not apply the input signals.

9.1.8. To prevent destruction of the elements by static electricity, be careful to maintain an optimum work environment.

9.1.8.1. Be sure to ground the body when handling the LCD Modules.

9.1.8.2. Tools required for assembly, such as soldering irons, must be properly ground.

9.1.8.3. To reduce the amount of static electricity generated, do not conduct assembly and other work under dry conditions.

9.1.8.4. The LCD Module is coated with a film to protect the display surface. Be care when peeling off this protective film since static electricity may be generated.